

Creality RaptorX

3D Scanner

Small To Large. Scan It, Make It

Quick Guide V1.0



1. PRODUCT INTRODUCTION

Creality RaptorX is a metrology-grade 3D scanner with a maximum accuracy of 0.02mm, and wireless scanning. It has three light sources (blue light, white light, and infrared), and can simultaneously achieve large-format high-speed scanning of cross-laser lines (34 lines), fine scanning of parallel laser lines (7 lines), and infrared scanning. It is suitable for scanning medium-to-large complex parts in the fields of automotive parts, reverse engineering, product design, energy engineering, and heavy industry, and can achieve full-size inspection, reverse design, 3D printing, additive manufacturing and other applications. It is also suitable for scanning targets such as human bodies, faces, and cultural relics. The matching wireless scanning handle allows RaptorX to get rid of the constraints of wires and has very good portability. When scanning wirelessly, the mobile phone can be used as the scanner screen, making the scanning process easier and more comfortable.

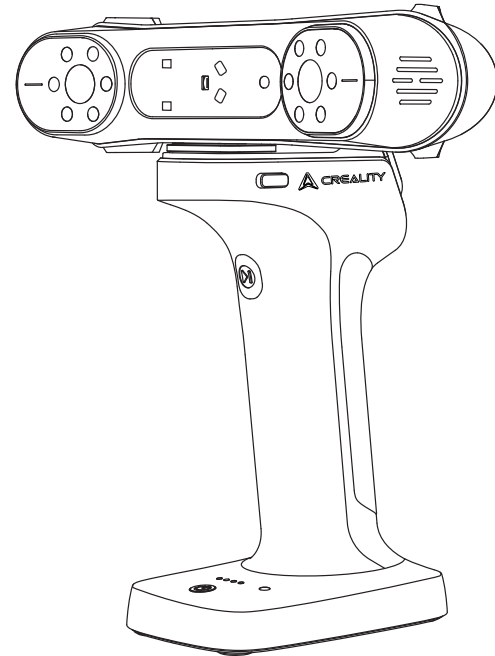



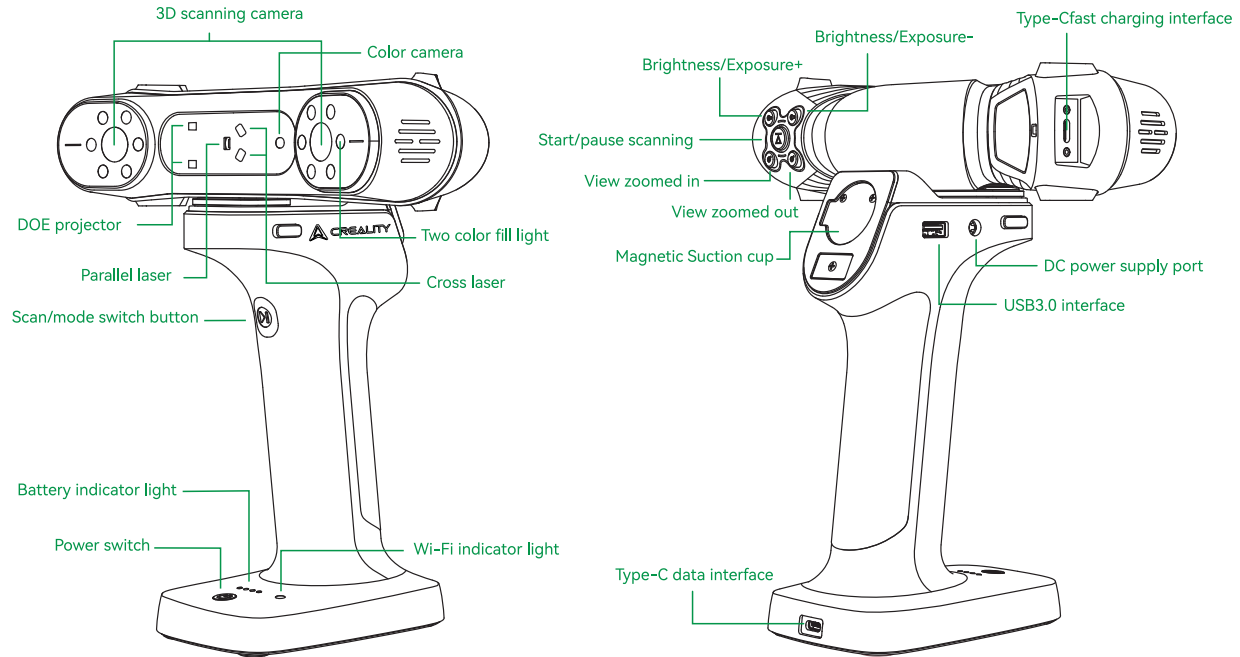

2. PRODUCT INFORMATION





2.1 Scanner Introduction









2.2 3D Scanner Button Description

Button	Scanner Feedback	Indicator light feedback
	Short press once to start scanning, press again to pause; long press ≥ 3 seconds to end scanning. Double-click to switch between 7-line or 17-line crossed laser modes.	The middle indicator light flashes once
	Short press to increase laser brightness by one level in parallel line mode, or increase IR camera exposure in infrared mode.	/
	Short press to decrease laser brightness or reduce IR camera exposure.	/
	Short press to zoom in.	/
	Short press to zoom out.	/

2.3 Wireless Scanning Charging Handle Buttons/Interface Description

Button	Wireless scanning charging handle feedback	Indicator light feedback
	Press once to turn on the power; Long press ($\geq 2s$) to turn off the power; Long press ($\geq 10s$) to force shutdown.	WiFi indicator turns blue
	Press once to start scanning; press again to pause scanning; press for ≥ 3 seconds to end scanning; double-click to switch between 7-line laser or 17-line cross laser.	/
	The Type-C charging port can charge the wireless scanning charging handle and supports 30W fast charging.	/
	12V_DC power supply interface, to power the scanner.	/
	USB3.0 communication interface, data communication interface between wireless scanning handle and scanner.	/









2.4 Indicator Light Instructions

Indicator light with color	Status or Meaning	Reference Color
Steady green	Device running normally or scanning distance is optimal.	
Flashing red	Device in abnormal state.	
Flashing yellow	Device in upgrade mode.	
Steady orange-red	Scanning distance too close.	
Steady orange	Scanning distance relatively close.	
Steady light blue	Scanning distance relatively far.	
Steady dark blue	Scanning distance is too far	

*When the distance indicator starts flashing during scanning, it means that the scanning tracking is lost and the scanner needs to return to the scanned area to restore the scanning stitching relationship.

*When the device is in standby mode, the indicator light will enter a breathing state to save power.

2.5 Wireless Scanning Charging Handle Indicator Light Description

Battery Indicator	Wireless Scanning Charging Handle Feedback
	<p>All 4 lights on indicate 75%-100% power.</p>
	<p>3 lights on indicate 50%-74% power.</p>
	<p>2 lights on indicate 15%-49% power.</p>
	<p>1 light on indicates <15% power, please charge soon.</p>
WiFi Status Indicator	Indicator Light Feedback
	<p>Steady blue light during startup, flashing blue when the device is ready.</p>
	<p>Steady green light when WiFi successfully connects with software.</p>
	<p>Steady red light when WiFi or upgrade fails.</p>
	<p>Steady yellow light during OTA upgrade.</p>

3. Wireless Scan Handle Product Parameters

Product Name	Scan Bridge
Scanner Compatibility	CR-Scan Otter, CR-Scan Raptor, Creality RaptorX
WiFi Protocols	WiFi6, backward compatible
Frequency band	5GHz
Transfer rate	Parallel line mode ≤ 50 fps; infrared mode ≤ 30 fps
Battery Type	Lithium battery
Battery capacity	5000mAh (2 pcs)
Fast charging power	30W
Fast charging protocol	PD/ AFC/FCP
Charging port	Type-C
Communication interface	USB-A/USB3.0
Power supply interface	DC12V/USB5V
Mobile phone holder	Magnetic
Power switch button	Mechanical
Scan switch button	Mechanical
size	193.7 mm x 119.8 mm x 81.7 mm
weight	444g
Operating temperature	-10°C to 40°C
Operating humidity	0-90%RH

4. 3D Scanner Product Parameters

Crealty RaptorX			
Scanning Mode	7 blue parallel laser lines	34 blue laser lines (cross)	NIR (Infrared binocular structured light)
Accuracy	Up to 0.02mm		Up to 0.1mm
Volume Accuracy	0.02mm+0.06mm/m		0.05mm+0.1 mm/m
Scanning Rate	420,000 measurements/s	1,020,000 measurements/s	3,580,000 measurements/s
3D Resolution	0.02-2mm		0.1-2mm
Scanning Speed	Up to 60fps		Up to 20fps
Minimum Scanning Volume	5mm x 5mm x 5mm		150mm x 150mm x 150mm
Single Capture Range	270mmx170mm@300mm	270mm x 170mm@300mm 341mm x 232mm@400mm 397mm x 290mm@500mm 452mm x 348mm@600mm (600mm TBD)	630mmx550mm@1000mm
Working Distance	150mm-400mm	200-600mm	170mm-1200mm

Color Mapping	Support		
Alignment Mode	Marker		Marker / geometry / texture
3D Imaging Camera Resolution	1920x1200		
RGB Color Supplemental Light	12 white LEDs		
Outdoor Scanning	Below 50,000 lux	Below 10,000 lux	Below 30,000
Marker Recognition Enhancement	12 blue LEDs		
Laser Safety	Class I(eye safe)	Class II (eye safe)	Class I(eye safe)
Button	Mechanical		
IMU	Support		
Output Format	OBJ/STL/PLY		
Input Power	12V 2A		

Data Interface	TypeC/USB3.0
Device Dimensions	215mmx50mmx74mm
Device Weight	405g
Calibration Board	High-precision glass calibration board
Wireless Scanning	Support
System Support	Windows/macOS
Operating Temperature	-10°C to 40°C
Operating Humidity	0-90%RH
[1] Accuracy is evaluated in laboratory conditions and actual results may be affected by operating environments such as temperature, vibration, and other factors.	

3. PACKING LIST

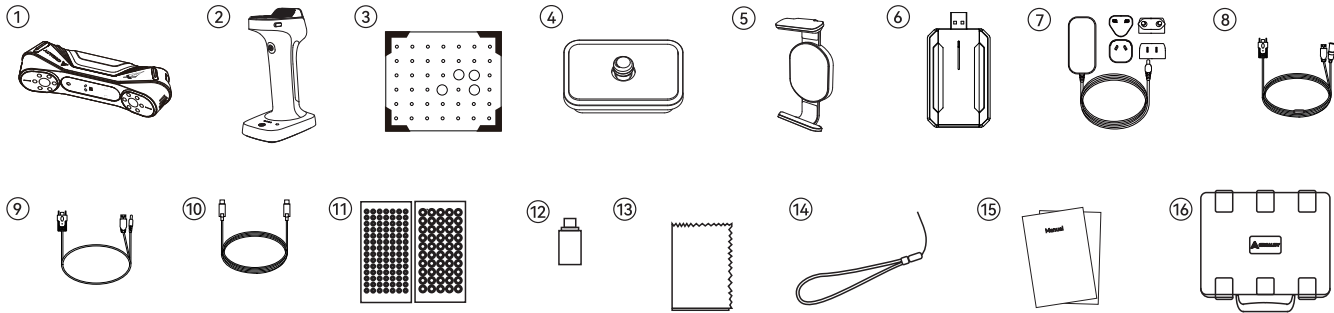

1. Creality RaptorX 3D Scanner	9. Scan Bridge Data Cable
2. Scan Bridge Wireless Scanning Charging Handle	10. Fast charging data cable
3. High Precision Glass Calibration Plate	11. Reflective marking points (D6mm*40 sheets, D3mm*40 sheets)
4. Hand-tightening quick-release card	12. Type-C Adapter
5. Magnetic phone holder	13. Cleaning cloth
6. WIFI 6 USB Wireless adapter	14. Lanyard
7. Adapter + adapter	15. Quick Operation Guide Certificate & Warranty Card
8. USB 3.0 data cable (Type-C/Type-A)	16. Safety Box

4. DEVICE CONNECTION

4.1 Wireless Scan Connection

1、 Install the RaptorX scanner onto the wireless scanning and charging handle as shown in the diagram.

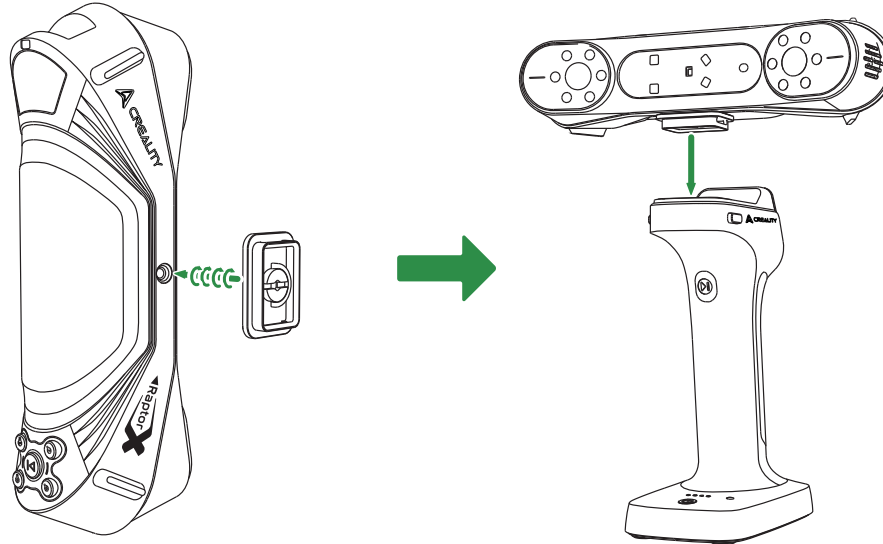

2、 Connect the USB 3.0 data cable to the 3D scanner and the wireless scanning charging handle as shown in the figure.

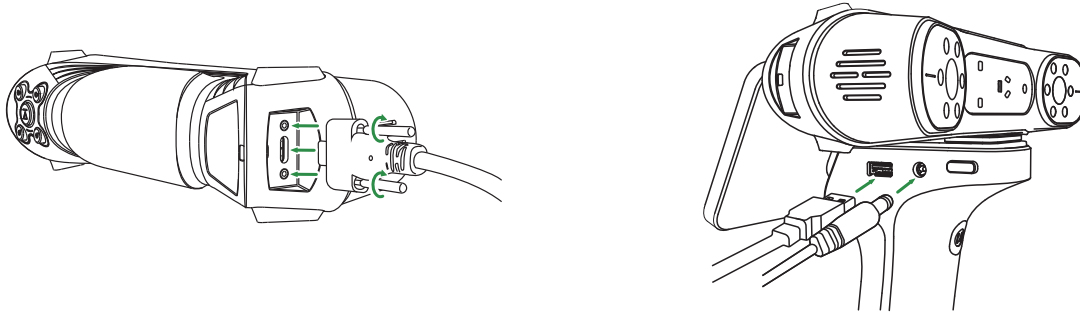

3、 Short press the power switch. When the WiFi status indicator turns blue and flashes, it means that WiFi is ready. Use your mobile phone to scan the wireless QR code to connect to WiFi, clip the magnetic mobile phone clip on the mobile phone and then fix it on the wireless scanning charging handle, as shown in the figure.

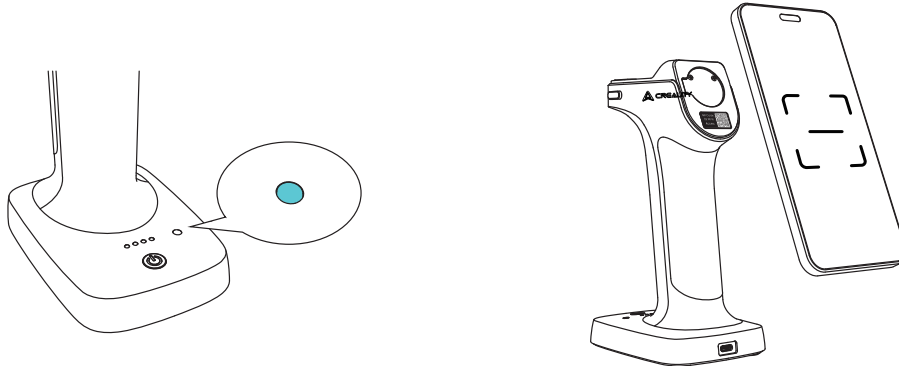

4、 Insert the wireless network card into the USB 3.0 port of the computer, connect the wireless network card to the wireless network of Scan Bridge, open the Crealty Scan software on the computer , select Wireless Screen Mirroring in the function bar on the right side of the software, and scan the Wireless Screen Mirroring QR code with your mobile phone to ensure that the software screen on the computer can be synchronized to the mobile phone, as shown in the figure .

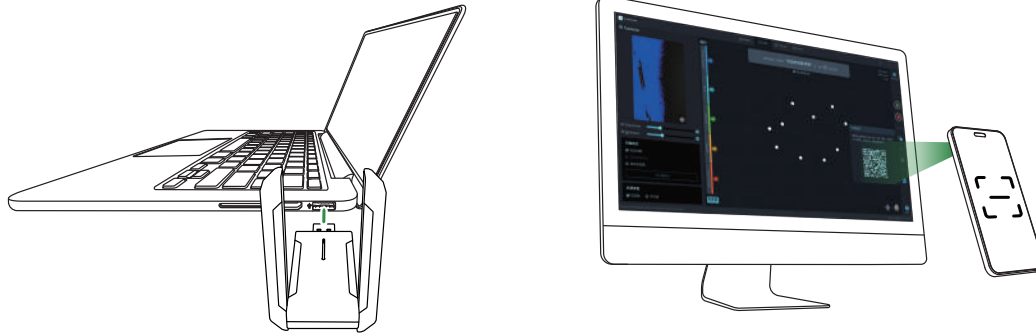

5、 Clip the magnetic phone holder onto the phone and then fix it on the wireless scanning charging handle to perform wireless scanning, as shown in the figure.



4.2 Wired Scan Connection

1. The user selects the appropriate adapter head according to the country they are in, then presses the adapter lock and pushes the selected adapter head upwards. The specific operation is shown in the figure below.

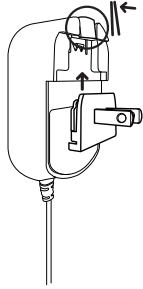

2. Device connection

- (1) Insert the Type-C port of the data cable into the device and tighten the screws.
 - (2) Connect the DC power cable female end of the data cable to the DC male end of the adapter.
 - (3) Plug the Type-A port of the data cable into the USB 3.0 port of the computer.
 - (4) Plug the adapter into a power socket.
- The specific operation is shown in the figure below

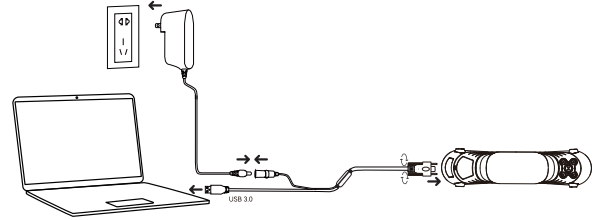

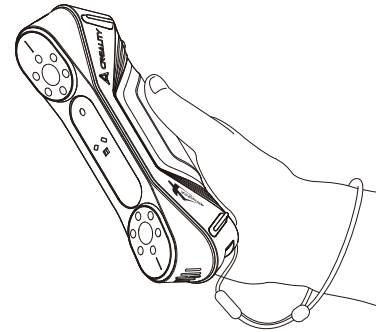

3. Use precautions

When using the device, tie the lanyard around your wrist (as shown in the below) to prevent the device from falling and causing damage.



5. CREALITY SCAN SOFTWARE SYSTEM OPERATION

5.1 Creality Scan Software System Requirements

System requirements		
	It is recommended to use a computer with the following configuration or higher: i7-Gen7 CPU, Nvidia graphics card (6GB video memory), 16GB memory Windows 10/11 (64bit) Software version: V3.3.0 or above	 Software Icon
	It is recommended to use M1/M2/M3 series processors and 16GB memory Software version: V3.3.0 or above	

5.2 Creality Scan software download and installation

Creality Scanner software download address: <https://wiki.creality.com/en/software>

Go to the official Creality Wiki software download page, click Creality Scan software, find the appropriate software version to download

Note: After you have completed the software installation on your MAC, please authorize the Creative 3D Scanner to read and write files so that you can optimize the point cloud and generate a model when using the software.

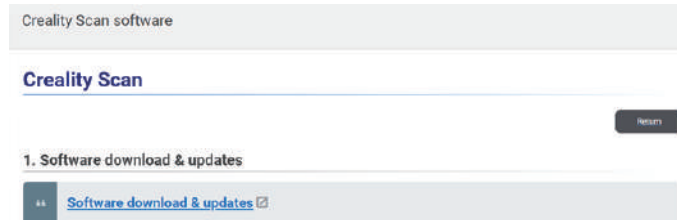

6. FIRST SCANNING

- (1) Connect the device and open the installed Creality Scan software.
- (2) Click [New Project] in the Creality Scan software, as shown below:



- (3) Enter the project name in the pop-up bar, select the folder path, and then click the [OK] button, as shown below

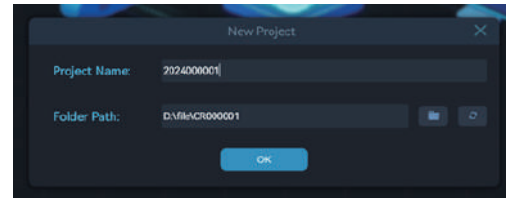

- (4) Enter "Model name", select "Folder path", and select the scanning mode and related configuration items according to the characteristics of the scan object. Finally, click the [Scan] button to enter the scan preview interface, as shown below

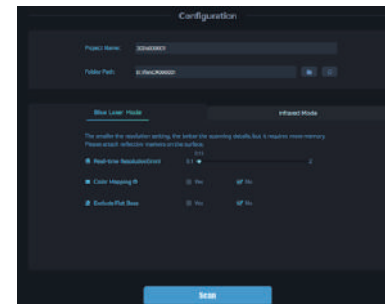

7. SCANNING STEPS

7.1 Scan mode selection

1、 If you need to scan the object with high precision and detail, please select the "Parallel Lines" mode in the " Laser Mode". In this case, you will need the assistance of marker points. If the object is small, you can stick the reflective marker on the table. You don't need to stick the marker on the surface of the object. If you want to scan the other side of the object, please use the multi-project stitching function of Creality Scan software to stitch the point clouds of multiple scans into a complete model. If the object is large, you need to stick the marker on the surface of the object.

If the object is large, you can select the "cross line" mode in the " laser mode". At this time, you need the assistance of marking points to perform high-speed scanning. When scanning in laser mode, you need to select an appropriate dot pitch. The smaller the dot pitch, the finer the scanned model will be, but it will consume more memory and may also affect the scanning frame rate.

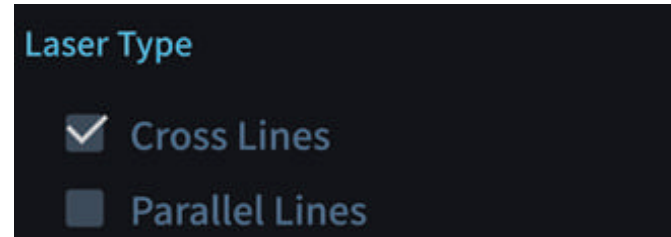

2、 Blue laser mode will result in higher resolution than selecting "Color".

Infrared mode can be used to scan targets such as faces and bodies without the need to attach markers. Infrared scanning also supports texture mode and marker mode scanning.

For more information about Creality RaptorX,

please visit: <https://wiki.creality.com/en/3d-scanner>

blue laser mode is as follows:

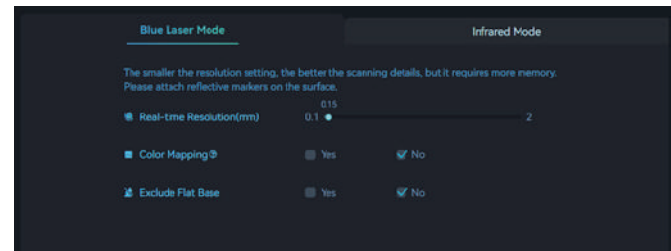

The reference configuration for infrared mode is as follows:

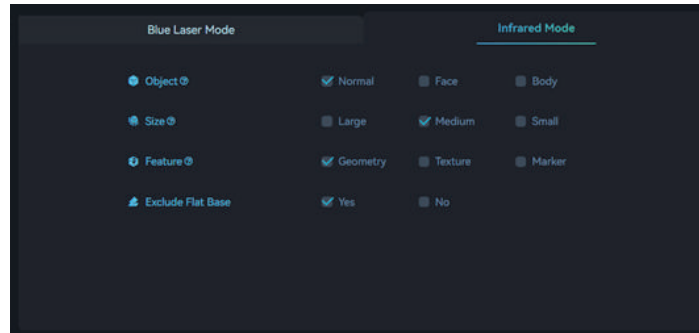

3. Adjust the scanner and the scanned test piece to a suitable distance, that is, when the scanner indicator light is green (as shown in the right figure), or the distance indicator bar on the software interface is at the best, it means that it is at the best scanning distance.

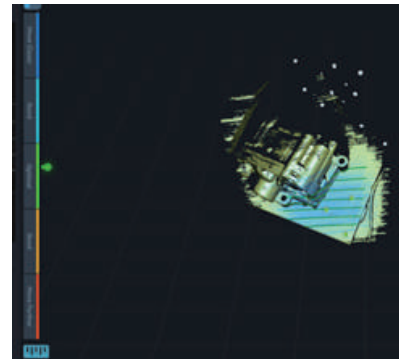
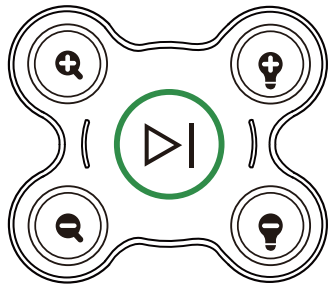

4. Short press the "Scan" button on the wireless scanning and charging handle, or short press the button on the scanner (H), or click (▶) the button on the software interface, and keep the scanner pointed at the object to start scanning.

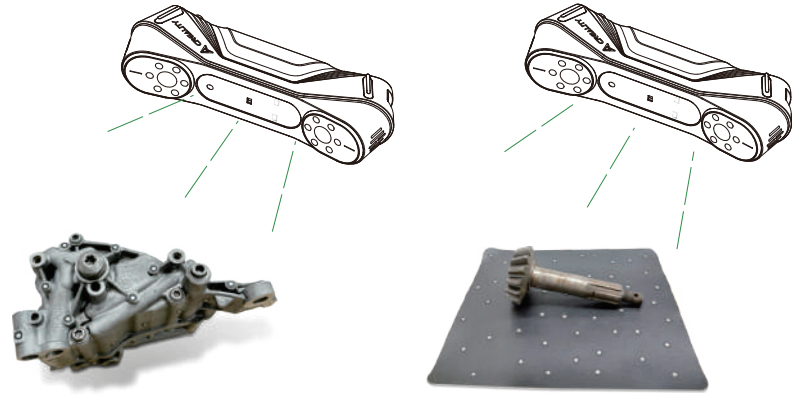

5. Use the scanner to perform a 360° scan of the object to be scanned. When the scan is completed, press and hold the "Scan" button on the wireless scanning charging handle for $\geq 3S$, or press and hold for more than 3S on the scanner (H), or click on the software interface (▶) to complete the scan. Perform post-processing in the Creality Scan software to obtain a complete 3D model (Please set the appropriate dot pitch). The effect is as shown on the right:

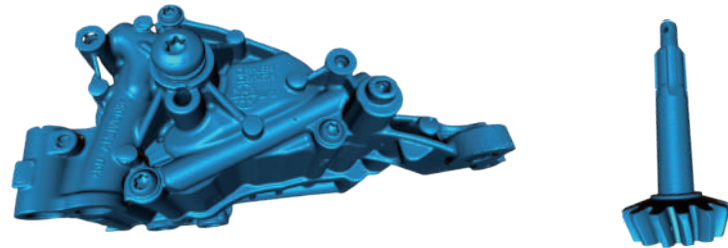

Note: The above button operations can also be performed in Creality Scan software. For specific software operations, please visit: <https://wiki.creality.com/3d-scanner>

8. FAQs

1. How to get better model details?

- ① The parallel line mode is more precise than the infrared mode;
- ② During the scanning process, adjust the exposure time of the IR camera to ensure moderate exposure; in parallel line mode, the laser intensity also needs to be adjusted;
- ③ Try to maintain the best distance;
- ④ When optimizing the point cloud, you need to set a smaller point distance; when the object size is small, the point distance can be set to 0.1mm (note that the smaller the point distance, the more memory and processing time will be consumed);
- ⑤ When constructing the mesh, the number of facets of the model should be set large enough.

For more scanning tips, please visit: <https://wiki.creality.com/3d-scanner>

2. How do I scan the bottom of an object?

- ① Creality Scan software provides the function of multi-project splicing, which can obtain a complete model of the object through multiple scanning and splicing;
 - ② First scan the visible part to get a partial model, then flip the object over and continue scanning through repositioning to get the complete model (this method is only applicable when the marking points are attached to the surface of the object).
- scanning through repositioning to get the complete model (this method is only applicable when the marking points are attached to the surface of the object).

3. How to charge the wireless controller?

When only one of the power indicator lights on the wireless controller is on, please charge it in time. For charging, please bring your own charging head for existing electronic products on the market, connect it to the fast charging data cable, and plug it into the type-c port at the rear end of the controller base to charge. When all four lights are not flashing, it means it is fully charged. Under normal circumstances, a 20V-1.5A (30W) charging head can be fully charged in only 2.5 hours, and the charging time of other charging heads varies according to the power.

4. When do you need to use the marker mode?

Parallel line mode and cross line mode require reflective marking points;

Infrared mode: When the geometric features of the object surface are not rich, you can stick reflective markers on the surface of the object and scan it in marker mode.

5. When can texture mode be used?

When the surface geometric features of an object are not rich but the texture is very rich (such as a vase), you can scan it directly using the texture mode.

6. When is calibration required?

when the device is not used for a long period of time (such as a week) or when it experiences a collision.

When high scanning accuracy is required, please calibrate before scanning.

7. Can I use the calibration plate from other scanner models?

The calibration plate of other scanner models cannot be used. Each time you calibrate, you need to scan the QR code on the back of the calibration plate first, otherwise the calibration accuracy will be affected. Please keep the calibration plate properly.

8. What precautions should be taken when storing calibration plates?

After each use, please carefully put the calibration plate back into the bag and keep it properly. Do not contaminate, scratch, or squeeze the calibration plate with heavy objects to avoid loss or damage of the calibration plate.

9. How to perform calibration?

Enter the [Quick Calibration] interface in the Creality Scan software and follow the animation prompts to calibrate.

9. TROUBLESHOOTING

● What to do if the system cannot recognize the scanner:

Confirm that the device cables are properly connected

If the device is connected correctly, try to reconnect the power cord to see if the scanner can be reconnected.

If it is still not connected, please connect the USB cable of the device first, then plug in the power cord

The Win computer cannot connect to the scanner;

If you are using a desktop computer, it is recommended to connect to the USB 3.0 port on the back of the host;

Confirm that you are using Windows 10/11 64bit system;

The installation path of the scanner software Creality Scan must be in an all-English path.

● What to do if you can't see the preview video stream in the application on Windows system?

Check whether the computer configuration meets the minimum configuration requirements of the scanner;

Check that the device is powered using the adapter that comes with the package and make sure it is connected properly;

Creality RaptorX ..." related camera in "Cameras" ;

Open Windows Settings - Privacy - Camera, confirm whether the system camera permission is turned on, and confirm whether the desktop application has permission to access the camera.

● What should I do if I can't see the preview video on the Mac application?

Check whether the computer configuration meets the minimum configuration requirements of the scanner;

Check that the device is powered using the adapter that comes with the package and make sure it is connected properly;

The scanner is updated to the latest firmware version;

Use a separate USB Type A to Thunderbolt or USB3 adapter. Try not to use a multi-function, multi-device USB C adapter.

Install CrealityScan directly in the App directory. Do not install it in a subdirectory under the App directory.

● In Windows system, what should I do if the USB3.0 interface is recognized as USB2.0?

You can try to quickly reinsert the USB cable, or connect the USB cable to the USB 3.0 port on the PC first, and then connect it to the USB type-C port on the scanner.

For more questions, please refer to the creality wiki :<https://wiki.creality.com/3d-scanner>

SHENZHEN CREALITY 3D TECHNOLOGY CO.,LTD.

Sitio web oficial: www.creality.com

Teléfono comercial: +86 755-8523 4565

Correo electrónico: cs@creality.com

Dirección de la empresa: Piso 18, Edificio JinXiuHongDu, Calle Meilong, Comunidad Xinni, Calle Minzhi, Distrito Longhua, Ciudad de Shenzhen, China.

Comunidad de Facebook
Análisis, información compartida
y localización de fallos



Creality wiki
La guía paso a paso para
ayudarle a empezar



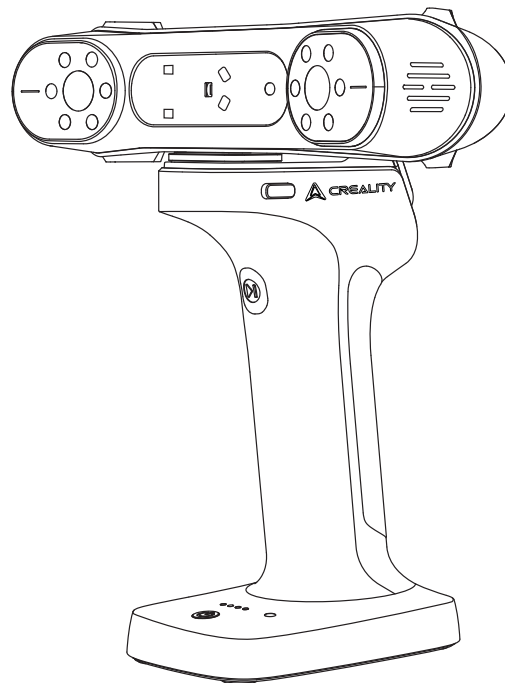

Creality RaptorX

3D 扫描仪

Small To Large. Scan It, Make It

一、产品简介

Creality RaptorX 是一款计量级3D扫描仪，且可以实现无线扫描。它拥有三种光源（蓝光、白光和红外），可同时实现交叉激光线大幅面高速扫描（34线）、平行激光线精细扫描（7线）以及红外扫描。适用于汽车配件、逆向工程、产品设计、能源工程以及重工业等领域的中大型复杂部件扫描，实现全尺寸检测、逆向设计、3D打印及增材制造等其他应用，也适用于人体、人脸、文物等目标的扫描。

配套的无线扫描手柄使得RaptorX可以摆脱线的束缚，具有非常好的便携性。无线扫描时，可用手机作为扫描仪的屏幕，使得扫描过程更加轻松自如。

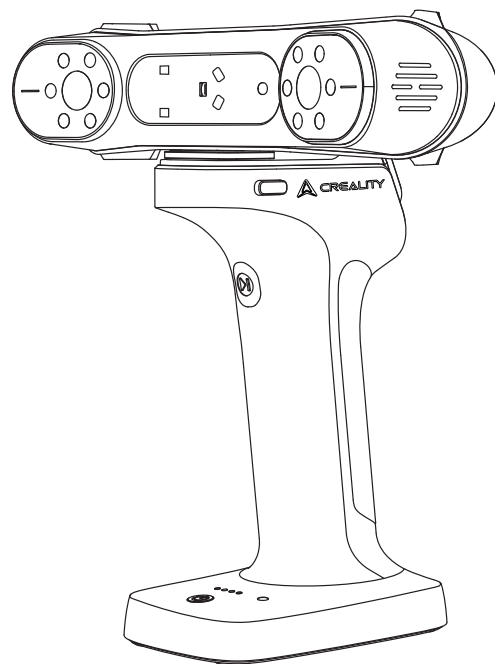



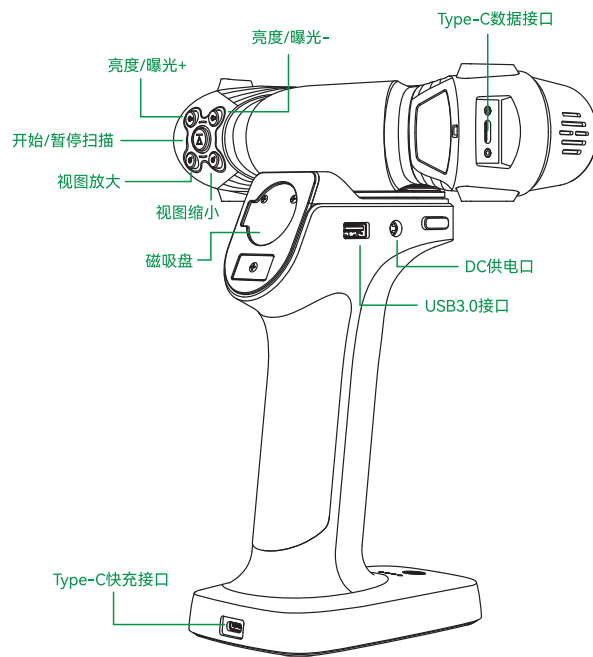
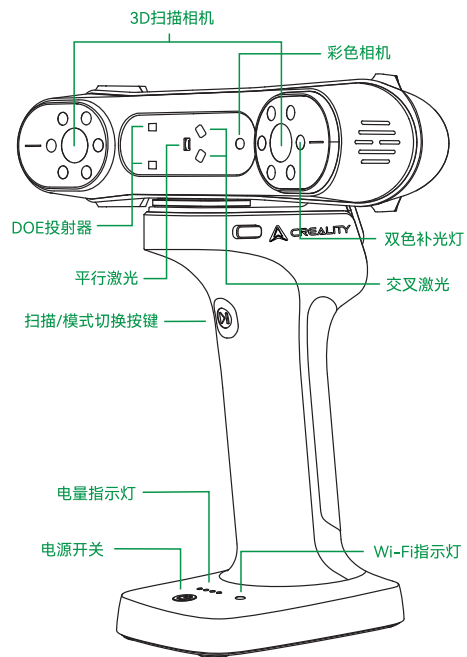

二、产品信息







2.1 设备简介







2.2 三维扫描仪按键说明

按键	扫描仪反馈	指示灯反馈
	短按一次，开始扫描；再短按一次，暂停扫描；长按≥3S，结束扫描。双击切换7线激光或17线交叉激光。	中间指示灯闪烁一次
	短按一次，平行线模式下调节激光亮度增强一级，红外模式下调节IR相机曝光增强一级；	/
	短按一次，平行线模式下调节激光亮度减弱一级，红外模式下调节IR相机曝光减弱一级；	/
	短按一次，视图放大一级；	/
	短按一次，视图缩小一级；	/

2.4 指示灯带说明

指示灯带颜色	状态或含义	参考颜色
绿色长亮	设备正常运行或扫描距离适中	
红色并闪烁	设备处于异常状态	
黄色并闪烁	设备处于升级状态	
橙红色长亮	扫描距离过近	
橙色长亮	扫描距离较近	
浅蓝色长亮	扫描距离较远	
深蓝色长亮	扫描距离过远	

2.3 无线扫描充电手柄按键/接口说明

按键	无线扫描充电手柄反馈	指示灯反馈
	短按一次，打开电源；长按2S以上，关闭电源；长按10S以上强制关机	wifi指示灯显示蓝色
	短按一次，开始扫描；再短按一次，暂停扫描；长按≥3S，结束扫描；双击切换7线激光或17线交叉激光。	/
	Type-C充电口，可以为无线扫描充电手柄充电，支持30W快充。	/
	12V_DC供电接口，为扫描仪供电。	/
	USB3.0通讯接口，无线扫描手柄和扫描仪的数据通讯接口。	/

*当在扫描中，距离指示灯开始闪烁时，意味着扫描跟踪丢失，需要扫描仪重新回到已经扫描过的区域，恢复扫描拼接关系。

*当设备待机时，指示灯会进入呼吸状态，以节省电量。

2.5 无线扫描充电手柄指示灯说明

电池电量指示灯	无线扫描充电手柄反馈
	<p>4个灯全亮表示当前电量在75%-100%;</p>
	<p>亮3个灯表示当前电量在50%-74%;</p>
	<p>亮2个灯表示当前电量在15%-49%;</p>
	<p>亮1个灯表示当前电量<15%，建议尽快给扫描仪充电。</p>
WiFi状态指示灯	指示灯反馈
	<p>当正常启动中时，长亮蓝灯；当设备启动完成，闪烁蓝灯</p>
	<p>当Wifi连接成功且与软件实现通讯，长亮绿灯</p>
	<p>当Wifi异常或升级异常时，长亮红灯</p>
	<p>当OTA升级过程中时，黄灯长亮</p>

3. 无线扫描手柄产品参数

产品名称	Scan Bridge
适配扫描仪	CR-Scan Otter、CR-Scan Raptor、Creality RaptorX
WiFi协议	WiFi6, 向下兼容
频段	5GHz
传输速率	平行线模式≤50fps; 红外模式≤30fps
电池类型	锂电池
电池容量	5000mAh (2节)
快充功率	30W
快充协议	PD/AFC/FCP
充电接口	Type-C
通讯接口	USB-A/USB3.0
供电接口	DC12V/USB5V
手机夹	磁吸式
电源开关按键	机械式
扫描开关按键	机械式
尺寸	193.7mm x 119.8mm x 81.7mm
重量	444g
工作温度	-10°C to 40°C
工作湿度	0-90%RH

4. 三维扫描仪产品参数

Creality RaptorX			
工作模式	蓝色7线激光	蓝色34线激光	红外双目结构光
精度	Up to 0.02mm		Up to 0.1mm
体积精度	0.02mm+0.06mm/m		0.05mm+0.1mm/m
扫描速率	420,000 点/秒	1,020,000 点/秒	3,580,000 点/秒
点距	0.02-2mm		0.1-2mm
扫描速度	最高60fps		最高20fps
最小扫描体积	5mm x 5mm x 5mm		150mm x 150mm x 150mm
幅面	270mmx170mm@300mm	270mm x 170mm@300mm 341mm x 232mm@400mm 397mm x 290mm@500mm 452mm x 348mm@600mm (600mm TBD)	630mmx550mm@1000mm
工作距离	150mm-400mm	200-600mm	170mm-1200mm

色彩贴图	支持		
拼接模式	标志点	标志点/几何/纹理	
3D成像相机分辨率	1920x1200		
RGB色彩补光灯	12颗白色LED		
户外扫描	50,000 lux以下	100,000 lux以下	30,000 lux以下
标志点补光灯	12颗蓝光LED		
激光安全	Class I(eye safe)	Class II (eye safe)	Class I(eye safe)
按键	机械式		
IMU	支持		
输出格式	OBJ/STL/PLY		
输入电源	12V 2A		

数据接口	TypeC/USB3.0
产品尺寸	215mmx50mmx74mm
产品重量	405g
标定板	高精度玻璃标定板
无线扫描	支持
系统支持	Windows/macOS
工作温度	-10°C to 40°C
工作湿度	0-90%RH
[1] 实验室条件下对尺寸探测误差 (PS) 和球心距测量误差 (SD) 进行评估, 实际测量结果将受包含温度、震动及其他因素在内的影响	

三、装箱清单

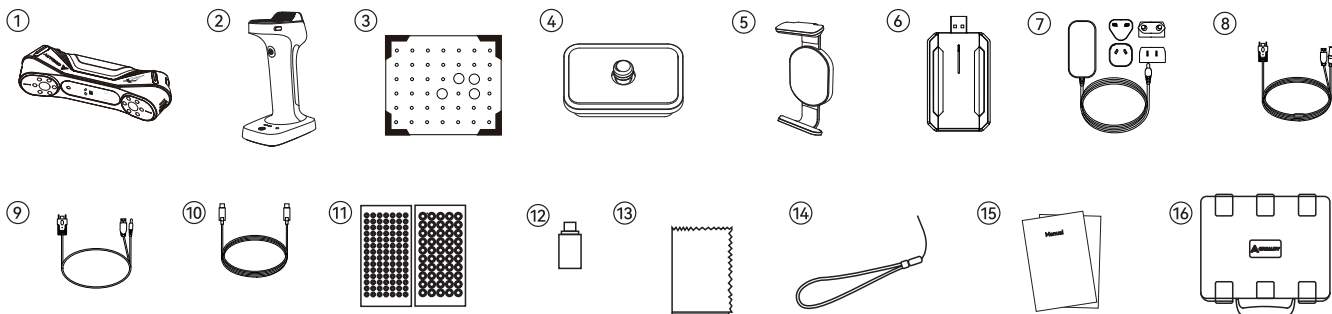

1. Creality RaptorX 3D扫描仪	9. Scan Bridge数据线
2. Scan Bridge无线扫描充电手柄	10. 快充数据线
3. 高精度玻璃标定板	11. 反光标志点 (D6mm*40张, D3mm*40张)
4. 手持快装卡	12. Type-C转接头
5. 磁吸手机夹	13. 清洁布
6. USB无线网卡	14. 挂绳
7. 适配器+转接头	15. 快速操作指南 合格证&保修卡
8. USB3.0数据线 (Type-C/Type-A)	16. 安全箱

四、设备连接

6.1 无线扫描连接

1、RaptorX扫描仪按照图示安装到无线扫描充电手柄上。

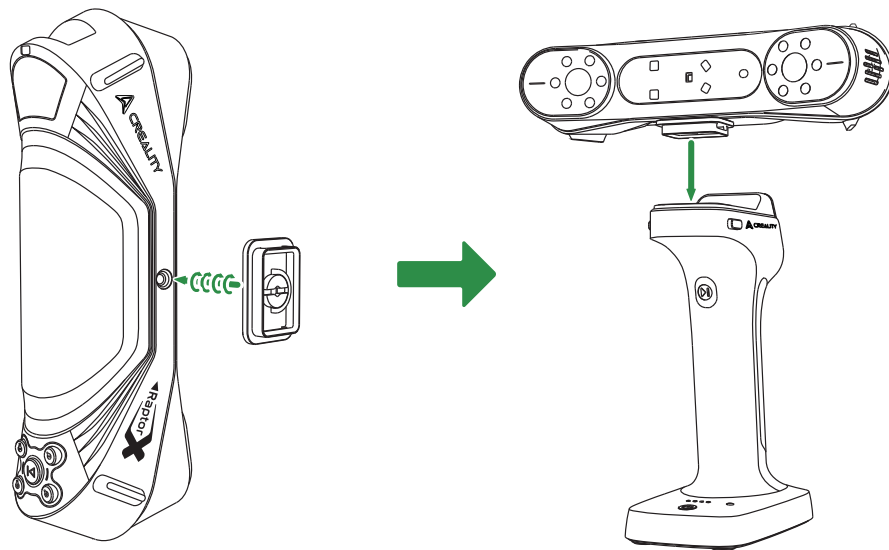

2、按照图示方式，用USB3.0专用数据线连接3D扫描仪和无线扫描手柄。

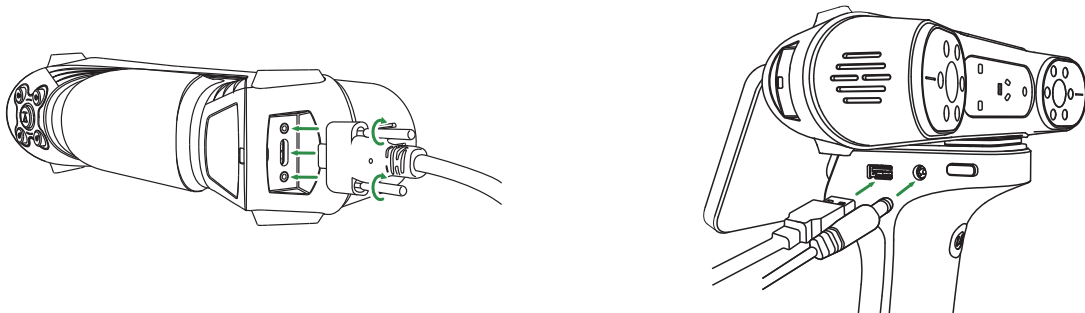

3、短按下电源开关，待WiFi状态指示灯变为蓝色并闪烁时，说明WiFi已经准备好，用手机扫描无线二维码连接WiFi，把磁吸手机夹夹在手机上，然后固定在无线扫描充电手柄上，如图所示。

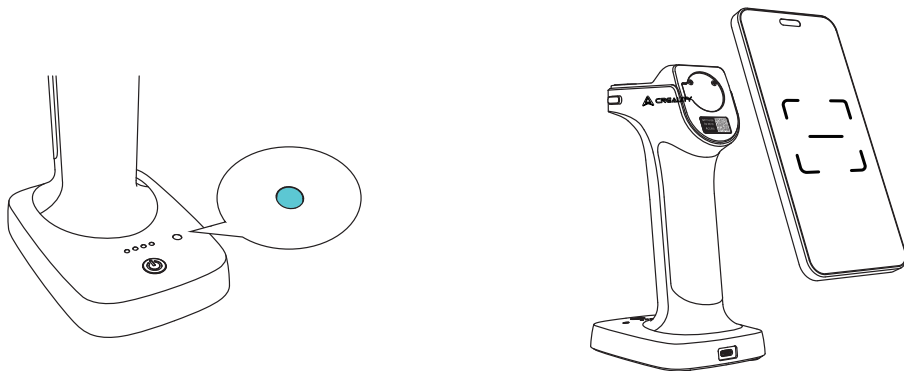

4、把无线网卡插入电脑USB3.0接口上，使无线网卡连接到Scan Bridge的无线网络，并在电脑端打开Creality Scan软件，选择软件右侧的功能栏中的无线投屏，用手机扫描无线投屏二维码，确保电脑端的软件画面能够同步到手机端，如图所示。

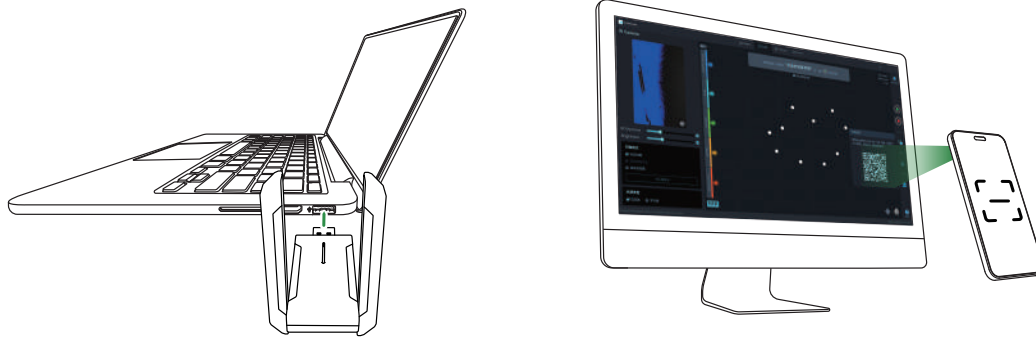

5、把磁吸手机夹夹在手机上，然后固定在无线扫描充电手柄上，即可进行无线扫描，如图所示。



6.2有线扫描连接

1、用户根据自己所在国家，选择合适的适配器转换头，然后按下适配器锁扣，并把选定的转换头往上推，具体操作如右图：

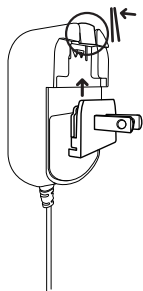

2、设备连接

- (1) 将数据线的Type-C接口插入设备中，并且锁紧螺钉。
- (2) 数据线的DC电源线母头和适配器的DC公头连接。
- (3) 数据线的Type-A接口插入电脑的USB3.0接口。
- (4) 适配器插入电源排插。

具体操作如右图示：

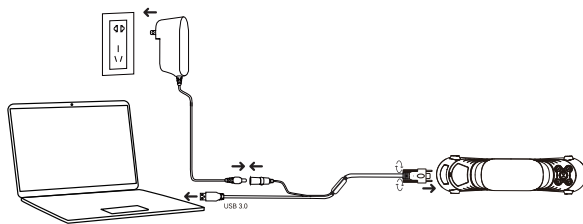

3、使用注意

使用设备时，挂绳系在手腕上（如右图），防止设备跌落，对设备造成损伤。

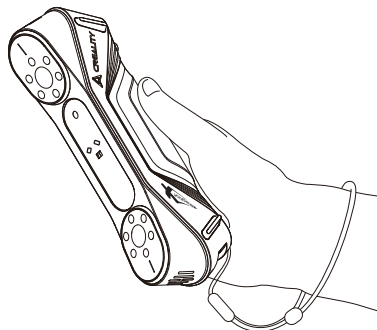

五、软件系统操作

7.1 Creality Scan软件系统要求

系统要求		
	推荐使用以下配置或更高的配置的电脑： i7-Gen7 CPU, Nvidia显卡（6GB显存），16GB内存 Windows 10/11 (64bit) 软件版本：V3.3.0以上	 软件图标
	推荐使用M1/M2/M3系列处理器，内存16GB 软件版本：V3.3.0以上	

7.2 Creality Scan软件下载及安装

创想扫描仪软件下载地址：<https://wiki.creality.com/en/software>

进入官方Creality Wiki软件下载网页，点击[Creality Scan software](#)，找到合适的软件版本进行下载

Creality Scan software

Creality Scan

learn

1. Software download & updates

Software download & updates

注意：您在MAC上完成软件安装后，请授权创想三维扫描仪读写文件的权限，以便在使用该软件时优化点云并生成模型。

六、首次扫描

- (1) 连接好设备，打开安装好的Creality Scan软件。
- (2) 在Creality Scan软件中点击【New Project】，如下图：



- (3) 在弹出栏输入工程名称，并选择文件夹路径，然后点击【OK】按钮，如右图

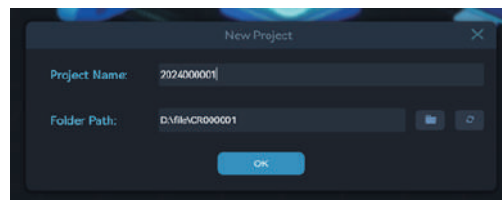

- (4) 输入“Model name”，选择“Folder path”，并根据扫描对象的特征选择扫描模式以及相关配置项。最后点击【Scan】按钮，进入扫描预览界面，如右图：

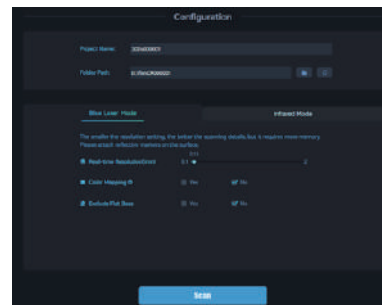

七、扫描步骤

一、扫描模式选择

1、如果需要对物体进行高精细节扫描，请选择“激光模式”中的“平行线”模式，此时需要标志点辅助。

物体较小时，可以将反光标志点贴在桌面上，物体表面不需要贴标志点。如要扫描物体的另一面，请用Creality Scan软件的多工程拼接功能，将多次扫描的点云拼接成一个完整的模型。如果物体较大时，需要把标志点贴在物体表面。

如果物体较大时，可以选择“激光模式”中的“交叉线”模式，此时需要标志点辅助，可以进行高速扫描。

使用激光模式扫描时，需要选择合适的点距。点距越小，扫描的模型越精细，但会消耗更多的内存，也可能会影响扫描帧率。



2、蓝色激光模式下选择“No Color”，精细度会比选择“Color”更高。

红外模式可以用于扫描人脸、人体等目标，无需贴标志点。红外扫描也支持纹理模式和标志点模式扫描。

如需了解更多关于Creality RaptorX的信息，

请访问：<https://wiki.creality.com/en/3d-scanner>

蓝色激光模式参考配置如下：

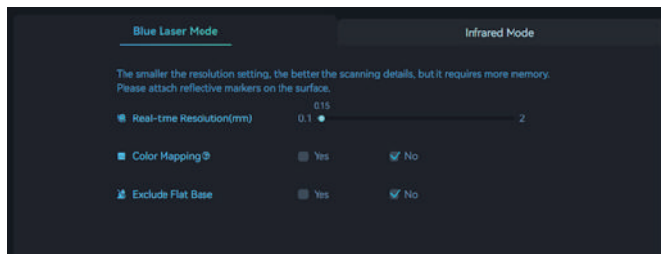

红外模式参考配置如下：

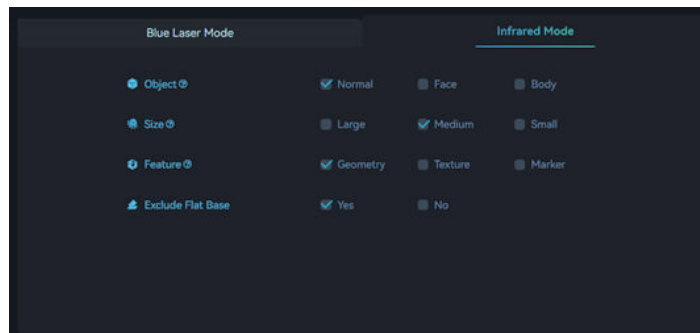

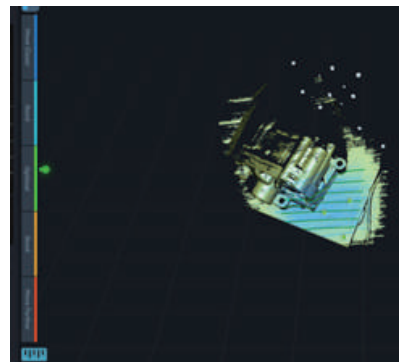
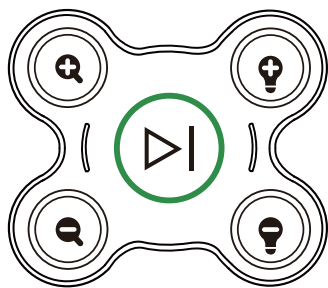

3、调整扫描仪和扫描测试件到合适距离，即扫描仪指示灯为绿色（如右图），或软件界面距离指示条处于最佳时，表示此时处于最佳扫描距离。

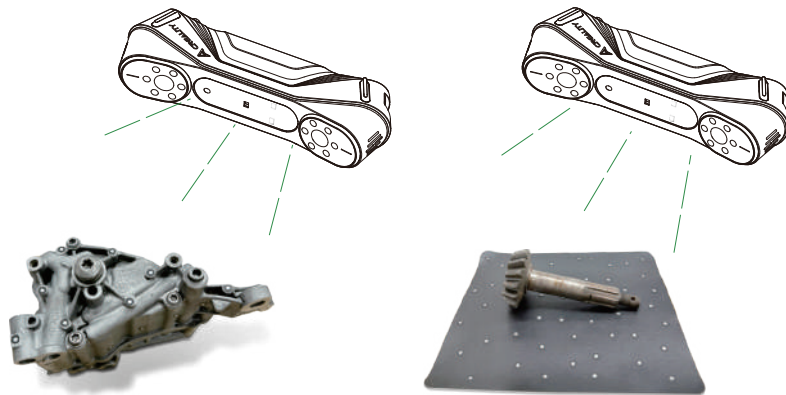

4、在无线扫描充电手柄上短按“扫描”按键，或扫描仪上短按  按键，或在软件界面点击  按钮，并保持扫描仪对准被扫描物，开始进行扫描。



5、用扫描仪对被扫描物进行360°扫描，当扫描完成时，在无线扫描充电手柄上长按“扫描”按键 $\geq 3S$ ，或在扫描仪上长按  超过3S，或在软件界面点击  ，即可完成扫描，在Creality Scan软件进行后处理即可得到完整的3D模型（设置合适的点距），效果如右图：



注：以上按键操作也可在Creality Scan软件操作，
软件具体操作可访问：<https://wiki.creality.com/3d-scanner>

八、常见问题

一、如何得到更好的模型细节？

- ① 平行线模式比红外模式精细度更高；
- ② 扫描过程中，调节合适的IR相机曝光时间，使得曝光适中；平行线模式下，还需要调节合适的激光强度；
- ③ 尽量保持最佳距离；
- ④ 在点云优化时，需要设置较小的点距；当物体尺寸较小时，点距可以调到0.1mm（注意，点距越小，会消耗更多的内存和处理时间）；
- ⑤ 构网时，模型的面片数要设的足够大。

了解更多的扫描技巧，请访问：<https://wiki.creality.com/3d-scanner>

二、如何扫描物体的底部？

- ① Creality Scan软件提供了多工程拼接的功能，可以通过多次扫描、拼接的方式，得到物体的完整模型；
- ② 先扫描可见部分得到部分模型，然后翻转物体，通过重定位继续扫描，得到完整的模型（该方式只适用于标记点贴在物体表面的情况）。

三、无线手柄如何充电？

当无线手柄电量提示灯只有一个灯亮时，请及时充电，充电请自备现有市面上电子产品的充电头连接上快充数据线，插在手柄底座后端的typec口进行充电，冲至4个灯都不闪烁了则代表充满了。一般情况下，20V-1.5A（30W）的充电头仅需2.5小时即可充满，其余充电头的充电时间则根据功率不同而异。

四、什么情况需要用标记点模式？

平行线模式和交叉线模式需要反光标记点；
红外模式：当物体表面几何特征不丰富时，可以在物体表面粘贴反光标记点，用标记点模式进行扫描。

五、什么情况可以用纹理模式？

当物体表面几何特征不丰富、但纹理很丰富时（如花瓶），可以直接用纹理模式进行扫描。

六、什么情况下需要标定？

当长时间不用（比如一周），或设备经历碰撞时需要标定一次。
对扫描精度要求很高时，扫描前请标定。

七、可以用其他型号扫描仪的标定板吗？

不能用其他型号扫描仪的标定板。每次标定时，需要先扫描一次标定板背面的二维码，否则会影响标定精度。请妥善保管好标定板。

八、标定板储存有什么注意事项？

每次使用完标定板后，请小心放回箱内妥善保管好，切勿污染，划伤，重物挤压标定板，避免标定板遗失或损坏。

九、如何进行标定？

在Creality Scan软件进入【快速标定】界面，按照动画提示进行标定即可。

九、故障排除

● 系统无法识别到扫描仪怎么办：

确认设备线缆均已正确连接

若设备正确连接，请尝试重新插拔电源，确认是否扫描仪可以重新连接
若仍未连接，请先连接设备的USB线缆，其次再插上电源线

● Win系统电脑连接不到扫描仪；

如果使用台式机，建议连接到主机背面的USB 3.0接口上；

确认使用windows 10/11 64bit的系统；

扫描仪软件Crealty Scan安装路径必须为全英文的路径下。

● 在win系统上的应用中看不到预览视频流怎么办；

检查电脑配置是否满足扫描仪最低配置要求；

检查是否使用随包赠送的适配器给设备供电，并确保其连接正常；

打开windows 设备管理器，在“Cameras”中查看是否有“Crealty RaptorX...”相关相机；

打开windows设置 - 隐私 - 相机，确认系统相机权限是否已打开，确认桌面应用是否有权限可以访问相机。

●在Mac系统的应用上看不到预览视频怎么办？

检查电脑配置是否满足扫描仪最低配置要求；

检查是否使用随包赠送的适配器给设备供电，并确保其连接正常；

扫描仪更新到最新固件版本；

使用独立的USB Type A转雷雳或USB3的转接头，请尽量不要使用多功能多设备的USB C转接器；

把CrealtyScan直接安装在.App目录下，请不要安装在.App目录下的子目录下。

●在win系统中，使用 USB3.0 接口被识别为USB2.0该怎么处理？

可尝试重新快速地插入USB线，或者先把USB线接入PC端的USB3.0接口，然后再接入扫描仪的 USB type-C接口。

其他更多问题请参考creality wiki: <https://wiki.crealty.com/en/3d-scanner>

深圳市创想三维科技股份有限公司

公司官网: www.crealty.cn 服务热线: 400 6133 882

电子邮箱: cs@creality.com

办公地址: 深圳市龙华区民治街道新牛社区梅龙大道锦绣鸿都大厦18F

工厂地址: 深圳市龙华区大浪街道浪口社区华旺路156号厂房

Comunidad de Facebook
Análisis, información compartida
y localización de fallos



Crealty wiki
La guía paso a paso para
ayudarle a empezar



WARRANTY

Name: _____ Telephone: _____

Address: _____ E-mail: _____

Serial Number: _____ Order Number: _____

Channel: Platform Offline Repair Change Return

Date of purchase Day _____ Mon. _____ Year _____

Malfunction And Damage Depiction Or Return And Change Reasons\Suggestions: _____

Repair Records: _____

Before returning the product and filling in a warranty, please contact after-sale person for going through after-sale formality. And attach this warranty card along with the returned machine.

Note: Client need filling in basic info, and return reasons. Repair records shall retain for technicians.

产品保修卡

客户名称: _____ 联系电话: _____

收件地址: _____ 电子邮箱: _____

机器制造编码: _____ 订单编号: _____

购买渠道: 电商平台 线下 返修 换货 退货

购买日期: _____ 年 _____ 月 _____ 日

故障描述或退、换货原因和建议: _____

维修情况记录: _____

产品寄回前请先联系售后专员,为正常进行售后处理,请务必填写此卡,并随机器寄回。

温馨提示:基本信息及返厂原因为客户必填项,维修情况记录部分为维修人员填写项



www.creality.com